

# SECTION E

## HYDRAULIC CYLINDERS

PAGE DESCRIPTION	PAGE
<b>PTE HYDRAULIC STREAMLINE SERIES</b>	
<b>SLM Series (MEDIUM DUTY CYLINDERS) .....</b>	<b>E 2</b>
<b>SLH Series(HEAVY DUTY CYLINDERS) .....</b>	<b>E 3</b>
<b>SLP Series (PHASING CYLINDERS) .....</b>	<b>E 4</b>
<b>SHP Series (HEAVY DUTY PHASING CYLINDERS).....</b>	<b>E 5</b>
<b>HP Series(HIGH PRESSURE HYDRAULIC CYLINDERS) .....</b>	<b>E 6</b>
<b>Available Mounting Styles for HP Cylinders.....</b>	<b>E 7</b>
<b>Spare Parts for PTE Cylinders .....</b>	<b>E 8</b>





## SLM Series

The **STREAMLINE MEDIUM DUTY**, or **SLM** hydraulic cylinder is a field proven design suitable for a vast majority of medium duty applications. The internally screwed front cap in conjunction with ports integrated within each end cap form the basis of the STREAMLINE design. These features, coupled with the use of high quality seals, makes it a popular option for use within both the mobile and industrial market sectors.

Max. Working pressure = 204 BAR 3000 psi  
 NB: For high pressure on long strokes refer to our technical dept. For column strength of rods etc.  
 High pressure T-seal on piston  
 Non standard rods and strokes available on request

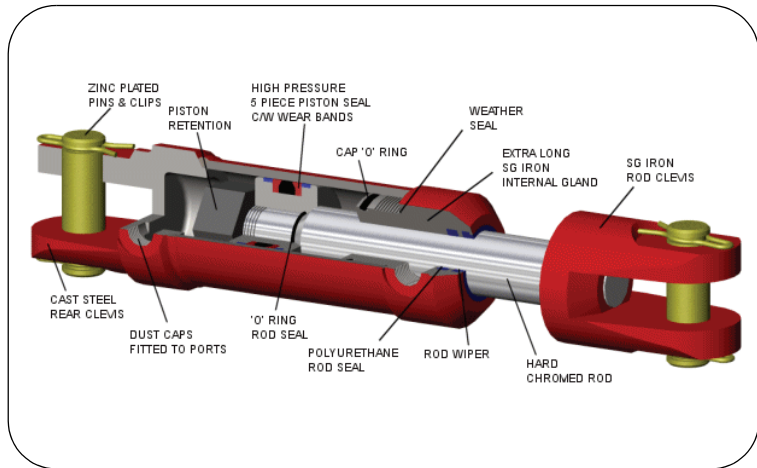

### PRICING

MODEL	BORE	ROD	Stroke															
			4"	6"	8"	10"	12"	16"	18"	20"	24"	30"	36"	48"				
SLM-15**	1 1/2"	7/8"	POA	POA	POA	POA	POA	POA	POA	POA	POA	POA	POA	POA	POA	POA	POA	POA
SLM-20**	2"	1"	POA	POA	POA	POA	POA	POA	POA	POA	POA	POA	POA	POA	POA	POA	POA	POA
SLM-25**	2 1/2"	1 1/2"	POA	POA	POA	POA	POA	POA	POA	POA	POA	POA	POA	POA	POA	POA	POA	POA
SLM-30**	3"	1 1/2"	POA	POA	POA	POA	POA	POA	POA	POA	POA	POA	POA	POA	POA	POA	POA	POA

NB: To complete the Model Code replace \*\* with the stroke length i.e. 8" = 08

MODEL	BORE	ROD	PORT	PIN	A	B	C	D	E	F	G	H	I	J	K	L	M	N
SLM15**	1.5"	7/8"	9/16"	3/4"	241	70	38	25	25	51	94	38	23	48	23	48	61	62
SLM20**	2.0"	1.0"	9/16"	3/4"	241	70	38	25	25	51	94	38	23	48	23	48	61	62
SLM25**	2.5"	1.5"	3/4"	1"	311	109	45	30	30	59	114	48	28	62	27	62	81	76
SLM30**	3.0"	1.5"	3/4"	1"	311	109	45	30	30	59	114	48	28	62	27	62	90	76

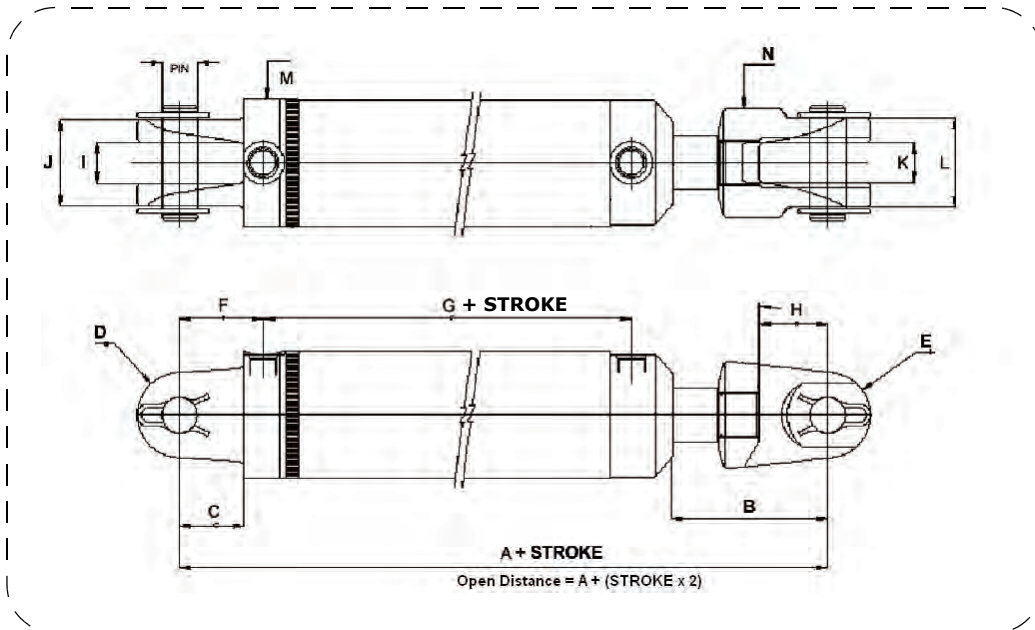



## SLH Series

The **STREAMLINE HEAVY DUTY**, or **SLH** hydraulic cylinder is a robust design for medium to heavy-duty applications. The cylinder has a number of features which allows it to perform under demanding industrial type loading situations where a medium level of shock loading and pressure spiking may occur.

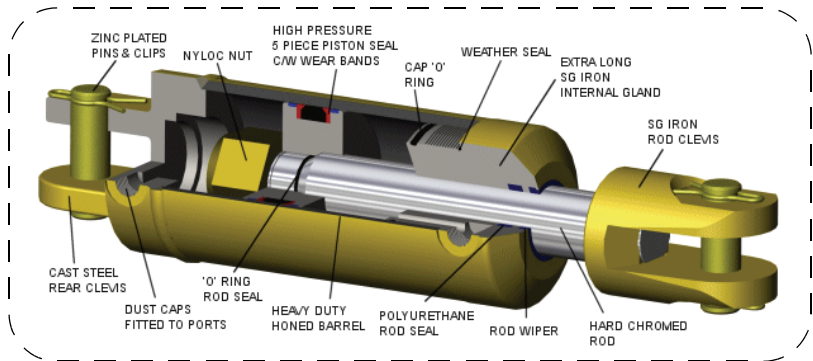

PRICING			Stroke									
MODEL	BORE	ROD	8"	12"	16"	18"	24"	30"	36"	42"	48"	
SLH-25**	2 1/2"	1 1/2"	POA	POA	POA	POA	POA	POA	POA	POA	POA	
SLH-30**	3"	1 1/2"	POA	POA	POA	POA	POA	POA	POA	POA	POA	
SLH-35**	3 1/2"	1 3/4"	POA	POA	POA	POA	POA	POA	POA	POA	POA	
SLH-40**	4"	1 3/4"	POA	POA	POA	POA	POA	POA	POA	POA	POA	
SLH-45**	4.5"	2"	POA	POA	POA	POA	POA	POA	POA	POA	POA	
SLH-50**	5"	2"	POA	POA	POA	POA	POA	POA	POA	POA	POA	

**NB:** To complete the part number replace \*\* with the stroke, i.e. 8" = 08

### DIMENSIONS

MODEL	BORE	ROD	PORT	PIN	A	B	C	D	E	F	G	H	I	J	K	L	M	N
SLH25**	2.5"	1.5"	3/4"	1"	311	109	45	30	30	59	114	48	28	62	27	62	81	76
SLH30**	3.0"	1.5"	3/4"	1"	311	109	45	30	30	49	114	48	28	62	27	62	90	76
SLH35**	3.5"	1.75"	3/4"	1"	311	87	43	32	35	59	136	48	30	62	27	62	102	80
SLH40**	4.0"	1.75"	3/4"	1"	311	87	43	32	35	59	136	48	30	62	27	62	115	80
SLH45**	4.5"	2.0"	3/4"	1 1/4"	311	84	43	35	35	57	138	48	30	70	27	62	127	80
SLH50**	5.0"	2.0"	3/4"	1 1/4"	311	84	43	35	35	57	138	48	30	70	27	62	140	80

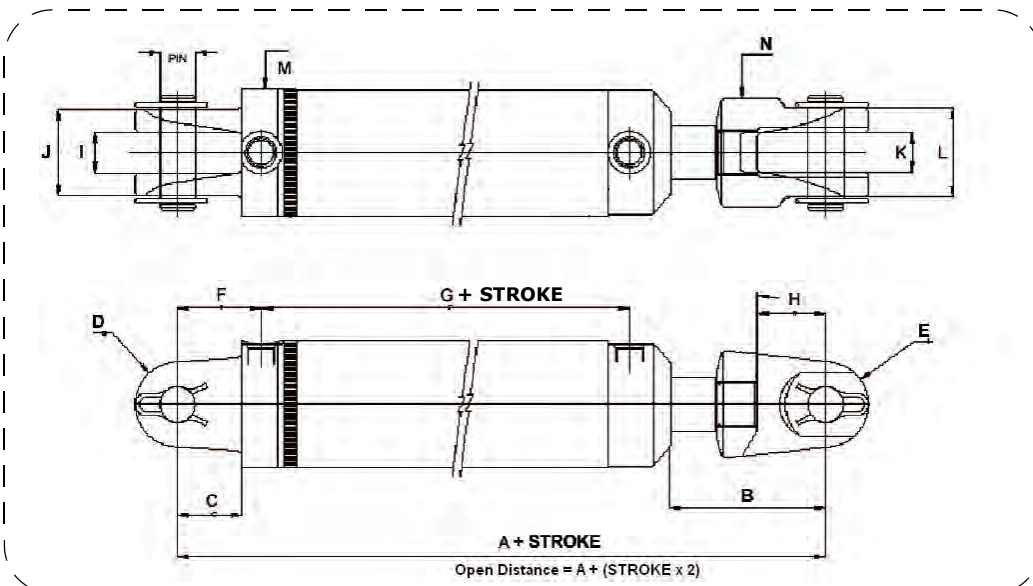

## SLP Series

The **STREAMLINE PHASING CYLINDER**, or **SLP** is based on the **SLH** design and benefits from the same design features but is fitted with the patented PTE re-phasing valve. The cylinders come in a range of sizes developed to form synchronised sets. The unique valve design allows for re-phasing of cylinders at either end of their stroke.

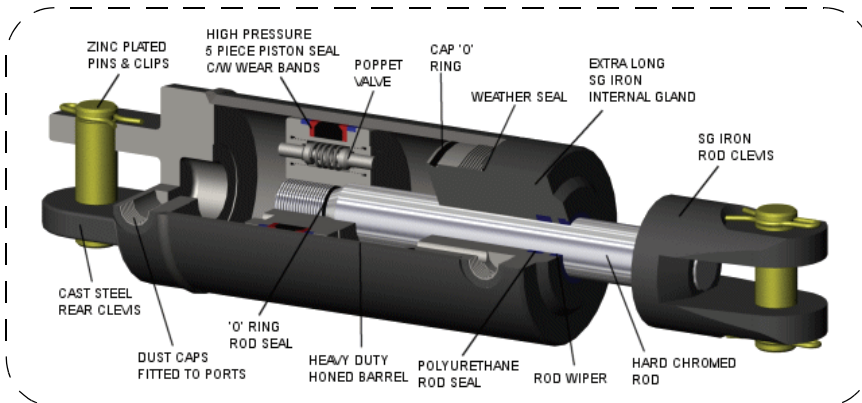

### PRICING

PRICING			Stroke								
MODEL	BORE	ROD	8"	12"	16"	18"	24"	30"	36"	42"	48"
SLP-250**	2.5"	1.125"	POA	POA	POA	POA	Price on Application				
SLP-275**	2.75"	1.125"	POA	POA	POA	POA					
SLP-300**	3.0"	1.25"	POA	POA	POA	POA					
SLP-325**	3.25"	1.25"	POA	POA	POA	POA					
SLP-350**	3.5"	1.25"	POA	POA	POA	POA					
SLP-375**	3.75"	1.375"	POA	POA	POA	POA					
SLP-400**	4.0"	1.375"	POA	POA	POA	POA					
SLP-425**	4.25"	1.375"	POA	POA	POA	POA					
SLP-450**	4.5"	1.5"	POA	POA	POA	POA					
SLP-475**	4.75"	1.5"	POA	POA	POA	POA					
SLP-500**	5.0"	1.5"	POA	POA	POA	POA					

### DIMENSIONS

**NB: To Complete the above Model Code Replace\*\* with the Stroke Length i.e. 8" = 08**

MODEL	BORE	ROD	PORT	PIN	A	B	C	D	E	F	G	H	I	J	K	L	M	N
SLP 250**	2.5"	1.125"	3/4"	1"	311	100	43	32	30	43	125	48	30	62	27	62	74	76
SLP 275**	2.75"	1.125"	3/4"	1"	311	100	43	32	30	43	125	48	30	62	27	62	81	76
SLP 300**	3.0"	1.25"	3/4"	1"	311	86	43	32	30	43	135	48	30	62	27	62	88	76
SLP 325**	3.25"	1.25"	3/4"	1"	311	86	43	32	30	43	135	48	30	62	27	62	105	76
SLP 350**	3.5"	1.375"	3/4"	1"	311	86	43	32	30	43	135	48	30	62	27	62	105	76
SLP 375**	3.75"	1.375"	3/4"	1"	311	86	43	32	30	43	135	48	30	62	27	62	108	76
SLP 400**	4.0"	1.375"	3/4"	1"	311	86	43	32	30	43	135	48	30	62	27	62	114	76
SLP 425**	4.25"	1.375"	3/4"	1"	311	86	43	32	30	43	135	48	30	62	27	62	121	76
SLP 450**	4.5"	1.5"	3/4"	1"	311	86	43	32	30	43	135	48	30	62	27	62	127	76
SLP 475**	4.75"	1.5"	3/4"	1"	311	86	43	32	30	43	135	48	30	62	27	62	134	76
SLP 500**	5.0"	1.5"	3/4"	1"	311	86	43	32	30	43	135	48	30	62	27	62	140	76

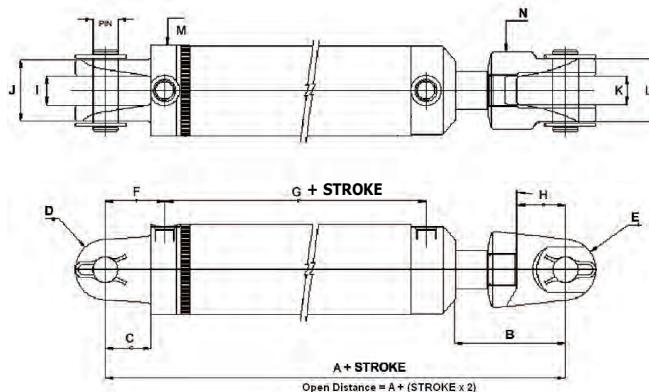

# STREAMLINE HEAVY-DUTY PHASING



## SHP Series

The **STREAMLINE HEAVY-DUTY PHASING CYLINDER**, or **SHP** is based on the **SLP** design and benefits from the same design features but is fitted with larger rods for heavy duty applications. The cylinders are available in 1/2" increments to form synchronised sets. The unique valve design allows for re-phasing of cylinders at either end of their stroke.

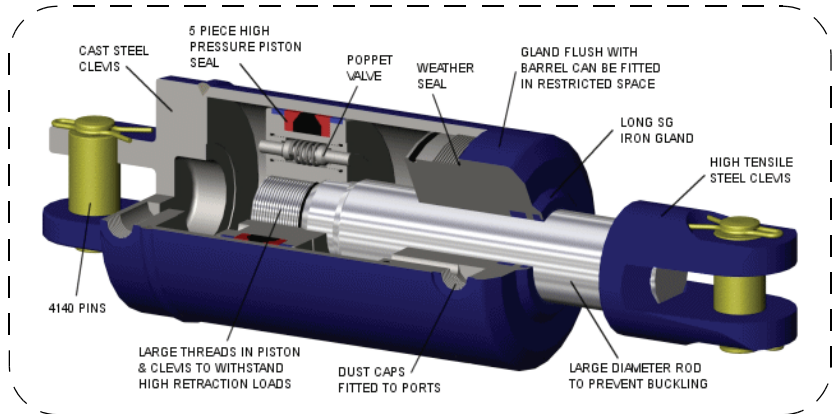

### PRICING

MODEL	BORE	ROD	STROKE			
			8"	12"	16"	18"
SHP- 400**	4"	2"	POA	POA	POA	POA
SHP- 450**	4-1/2"	2"	POA	POA	POA	POA
SHP- 500**	5"	55mm	POA	POA	POA	POA
SHP-550**	5-1/2"	2-1/4"	POA	POA	POA	POA

NB: To complete the part number replace \*\* with the stroke, ie 8" = 08

### DIMENSIONS

MODEL	BORE	ROD	PORT	PIN	A	B	C	D	E	F	G	H	I	J	K	L	M	N
SHP-400**	4.0"	2.0"	3/4"	1 1/4"	311	87	43	32	35	57	135	48	30	62	27	62	115	80
SHP-450**	4.5"	2.0"	3/4"	1 1/4"	311	87	43	32	35	57	135	48	30	62	27	62	127	80
SHP-500**	5.0"	55mm	3/4"	1 1/4"	311	87	43	32	35	57	135	48	30	62	27	62	140	80
SHP- 550**	5.5"	2.25"	3/4"	1 1/4"	311	87	43	32	35	57	135	48	30	62	27	62	159	80

For higher pressure applications please contact our technical dept. For alternative clevis & pin information.

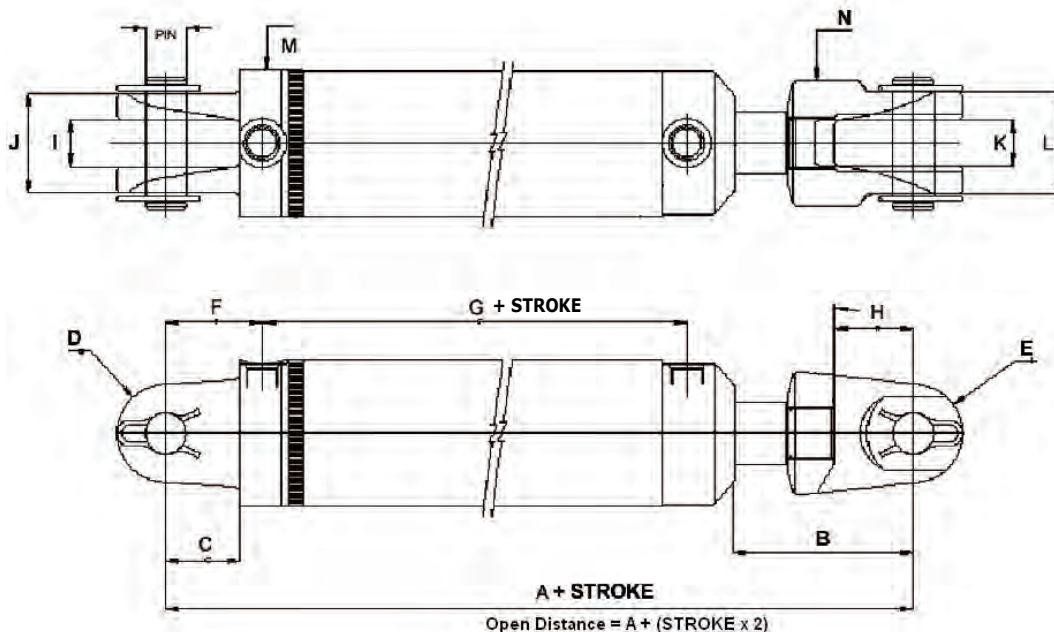

# HP Series

High Pressure Hydraulic Cylinders

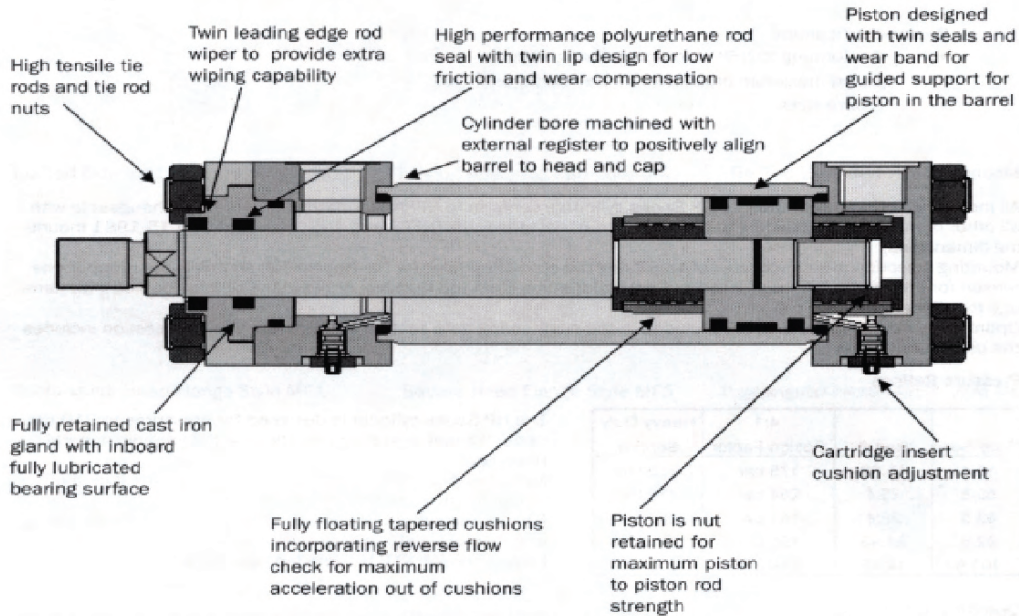

**210 BAR continuous pressure conforming to NFPA and ANSI Standard B93.15-1981**

**350 BAR non-shock capability**

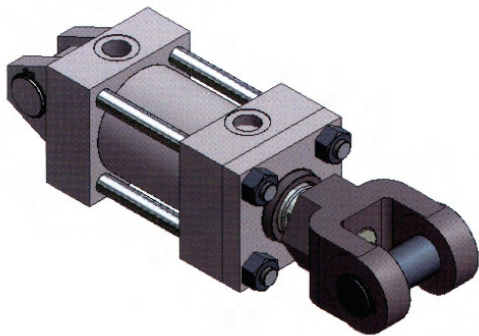

**PRICING ON APPLICATION**

BORE	ROD #	ROD DIAM	PORT BSPP
1 1/2"	1	5/8"	1/2"
1 1/2"	2	1"	1/2"
2"	1	1"	1/2"
2"	2	1 3/8"	1/2"
2 1/2"	1	1"	1/2"
2 1/2"	2	1 3/8"	1/2"
3 1/4"	1	1 3/8"	3/4"
3 1/4"	2	1 3/4"	3/4"
4"	1	1 3/4"	3/4"
4"	2	2"	3/4"



**Available Mounting Styles**

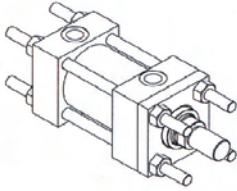

Tie Rod Extended Both Ends Style MX1

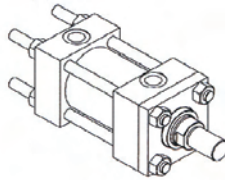

Tie Rod Extended Cap Style MX2

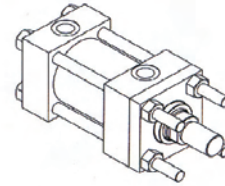

Tie Rod Extended Head Style MX3

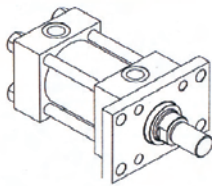

Rectangular Head Flange Style MF1

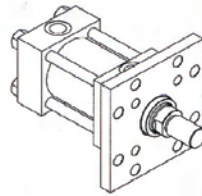

Square Head Flange Style MF5

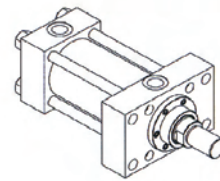

Rectangular Head Mount Style ME5

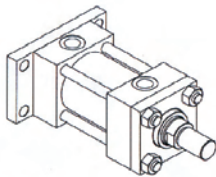

Rectangular Cap Flange Style MF2

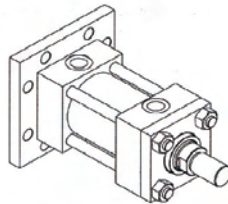

Square Cap Flange Style MF6

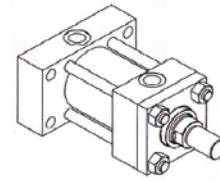

Rectangular Cap Mount Style ME6

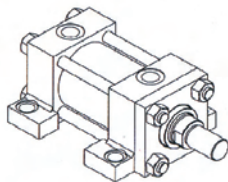

Side Lug Style MS2

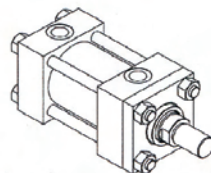

Tapped Mount Style MS4

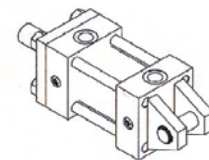

Cap Fixed Clevis Style MP1

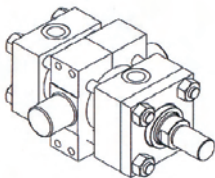

Center Trunnion Style MT4

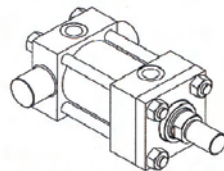

Cap Trunnion Style MT2

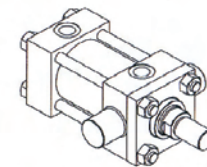

Head Trunnion Style MT1

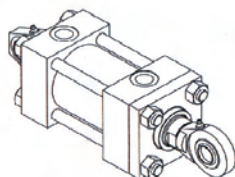

Spherical Bearing Style SB

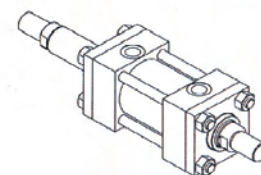

Double Rod Style

## Spare Parts for PTE Cylinders



Model	Description	List Price
SK-SLM150-7/8	SEAL KIT	POA
SK-SLM200-1.0	SEAL KIT	POA
SK-SLM250-1.5	SEAL KIT	POA
SK-SLM300-1.5	SEAL KIT	POA
SK-SLH250-1.5	SEAL KIT	POA
SK-SLH300-1.5	SEAL KIT	POA
SK-SLH350-1.75	SEAL KIT	POA
SK-SLH400-1.75	SEAL KIT	POA
SK-SLH450-2.0	SEAL KIT	POA
SK-SLH500-2.0	SEAL KIT	POA
SK-SHP400-2.0	SEAL KIT	POA
SK-SHP450-2.0	SEAL KIT	POA
SK-SHP500-55mm	SEAL KIT	POA
SK-SHP550-2.25	SEAL KIT	POA
SK-SLP250-1.125	SEAL KIT	POA
SK-SLP275-1.125	SEAL KIT	POA
SK-SLP300-1.25	SEAL KIT	POA
SK-SLP325-1.25	SEAL KIT	POA
SK-SLP350-1.25	SEAL KIT	POA
SK-SLP375-1.38	SEAL KIT	POA
SK-SLP400-1.38	SEAL KIT	POA
SK-SLP425-1.375	SEAL KIT	POA
SK-SLP450-1.5	SEAL KIT	POA
SK-SLP475-1.5	SEAL KIT	POA
SK-SLP500-1.5	SEAL KIT	POA
SLM-PIN-3/4	CLEVIS PIN 3/4"	POA
SLM-PIN-1	CLEVIS PIN 1"	POA
SLM-CLIP-3/4	CLIP - CLEVIS PIN 3/4"	POA
SLM-CLIP-1	CLIP - CLEVIS PIN 1"	POA